

Instruction and Maintenance Manual

RADIOLOGICAL SURVEY METER
OCDM Item No. CD-700, Model No. 6 and Model No. 6A

Manufactured 1961

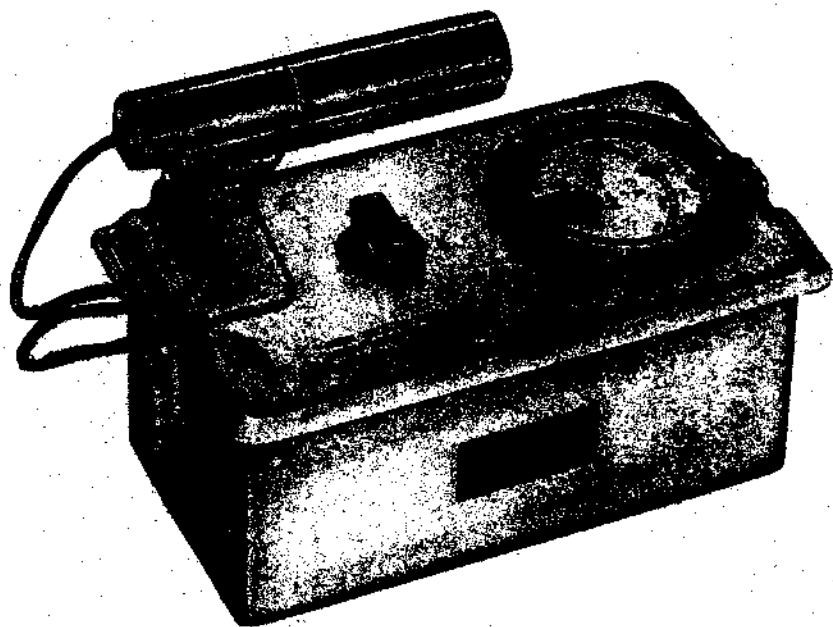

THE VICTOR INSTRUMENT COMPANY
5806 HOUGH AVENUE • CLEVELAND 3, OHIO

TABLE OF CONTENTS

SECTION 1. PRECAUTIONS

Paragraph	Page
1.1 Precautions	3

SECTION 2. GENERAL DESCRIPTION

2.1 Introduction	3
2.2 The Probe	3
2.3 The Circuit Box	3
2.4 The Head Phone	3
2.5 The Carrying Strap	3

SECTION 3. THEORY OF OPERATION

3.1 Introduction	4
3.2 The Geiger Tube	4
3.3 The High Voltage Supply..	4
3.4 The Pulse Shaping and Metering Circuit	4
3.5 Scale Ranges	5
3.6 The Headphone Circuit.....	5

SECTION 4. INSTALLATION

4.1 Installing The Batteries....	5
----------------------------------	---

SECTION 5. OPERATION

5.1 Operating The Circuit The First Time	7
5.2 Calibration	7
5.3 Scale Ranges	7
5.4 Using The Headphones	7
5.5 Normal Background	7
5.6 Checking Calibration	8
5.7 Using The Carrying Strap..	3

SECTION 6. OPERATOR'S MAINTENANCE

Paragraph	Page
6.1 Battery Replacement	8

SECTION 7. PREVENTIVE MAINTENANCE

7.1 Battery Life	9
7.2 Storage	9

SECTION 8. CORRECTIVE MAINTENANCE

8.1 Replacing The Batteries ..	9
8.2 Replacing The Geiger Tube	9
8.3 Checking The High Voltage Supply	9
8.4 Checking The Pulse Shaping and Integrating Circuit	10
8.5 Testing For Proper Operation Of The Range Switch	10

SECTION 9. REPLACEABLE PARTS LIST

9.1 Electrical Components	12-13
9.2 Mechanical Components	14-15
9.3 List of Manufacturers.....	16

LIST OF ILLUSTRATIONS

Figure	Page
1. View of CD V-700, Model No. 6, Showing Operating Controls	2
2. View of CD V-700, Model No. 6, Showing Major Components	6
3. CD V-700, Model No. 6, Schematic Circuit Diagram	11

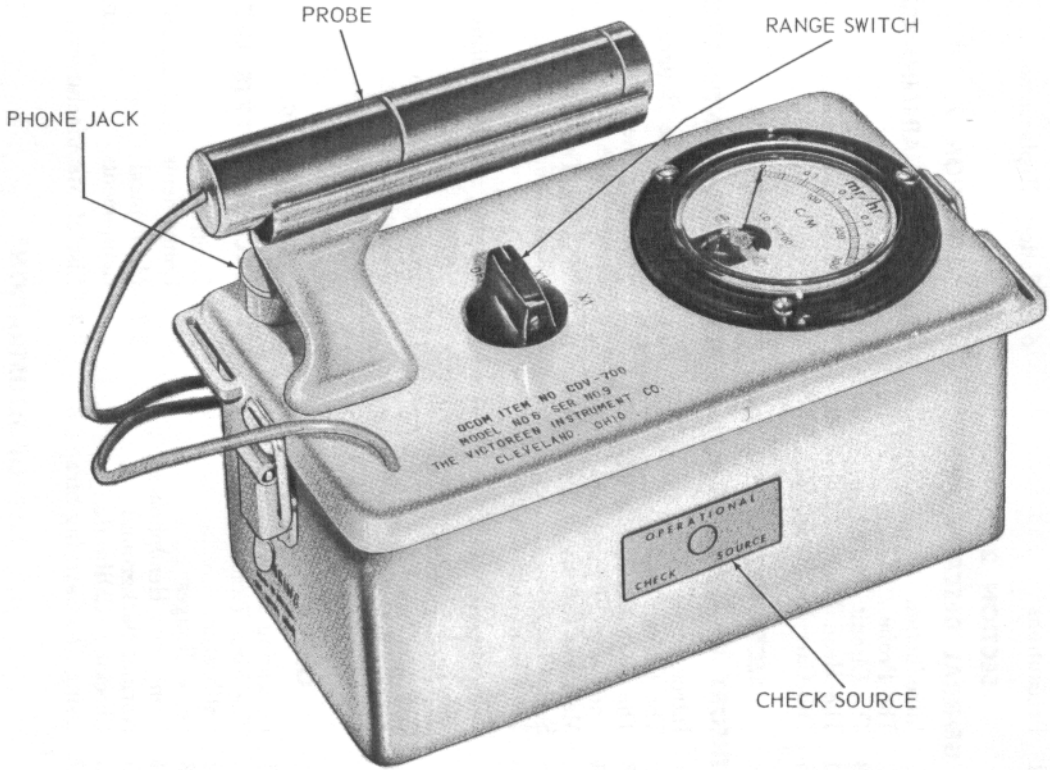

Figure 1. View of CDV-700, Model No. 6, Showing Operating Controls

1. PRECAUTIONS

1.1 PRECAUTIONS:

Although this instrument is operated from four "D" cells, the high voltage power supply operates at voltages in excess of 900 volts which constitutes a shock hazard if not handled carefully. The power supply high voltage components are located near the high voltage transformer at the rear of the circuit board. These components should not be touched, even when the instrument is "OFF", until the high voltage capacitors are discharged. The method of discharging these capacitors is to short-circuit the two leads of the corona regulator tube V2 with a screwdriver which has an insulated handle.

2. GENERAL DESCRIPTION

2.1 INTRODUCTION:

This instrument is a portable survey meter using a geiger tube as the detector. The geiger tube is mounted in a probe on the end of a thirty-six inch cable. The entire instrument and its accessories comprise a circuit box, a probe, a headphone and a carrying strap; a radioactive sample is mounted on the side of the case.

2.2 THE PROBE:

The probe comprises a nickel-plated brass shield with a window which may be opened in order to admit beta radiation. Within the probe is mounted a plug-in type geiger tube which is sensitive to moderate and high energy beta radiation and to gamma radiation down to low energies. Because the geiger tube is fragile, shock mounts are provided on both ends of the tube. In addition, rubber gasketing is used to seal against moisture.

2.3 THE CIRCUIT BOX:

The circuit box consists of the supply batteries, an electronic high voltage supply, an electronic pulse shaping and metering circuit and a radioactive sample. The system is shockproof and waterproof and is secured with rapid take-down clamps in order to make access very simple. The entire electronic circuit is mounted on a single card with connections going to the probe, the phone connector and to the meter. The batteries are housed in a high-impact resistant plastic case which cannot be corroded by leaking battery fluids. The battery contacts are readily replaceable without tools to facilitate cleaning or replacement. The battery box is designed to be mechanically selective so that batteries cannot be inserted backwards.

2.4 THE HEAD PHONE:

The head phone is a single piece magnetic type device with a connector suitable for the sealed jack mounted on the circuit box.

2.5 THE CARRYING STRAP:

The carrying strap, made of vinyl for easy decontamination, is provided with easily operated spring clips.

3. THEORY OF OPERATION

3.1 INTRODUCTION:

Operationally this instrument consists of a geiger tube radiation detector, a regulated high voltage supply, a pulse shaping and metering circuit, an indicating meter and headphone for audible detection of activity.

3.2 THE GEIGER TUBE:

The geiger tube is a gas filled device which detects the presence of ionization within its gaseous volume. The ionization results from the passage of ionizing type radiation through the gas. The primary type of radiation it detects is beta rays (high speed electrons). These are produced as a primary breakdown product of radioactive substances and in addition are produced within the geiger tube and within the walls of the probe by gamma radiation. A shield is provided which stops external beta radiation, thus making the detector sensitive to gamma radiation only, but a window in the probe may be opened to make the system sensitive to beta radiation also. The geiger tube operates at 900 volts which is essentially the center of a plateau extending from about 850 volts to about 920 volts.

3.3 THE HIGH VOLTAGE SUPPLY:

The high voltage power supply is a blocking oscillator driven "fly-back" type circuit. The blocking oscillator portion of the circuit consists of Q_2 , R7B, transformer windings 3-4 and 5-6, and batteries BT1-2. When the instrument is turned "ON", Q_2 conducts and an increasing current flows through winding 3-4. This increasing collector current induces a voltage in winding 5-6 which maintains conduction of Q_2 . The collector current increases until Q_2 has insufficient current gain to remain saturated when the circuit rapidly turns "OFF" due to the regenerative action of the transformer. During the "turn-off" action, large "fly-back" voltages appear across all transformer windings. A voltage peak of about 1100 volts appears across winding 1-2 because of the large number of turns in the winding. This voltage "fly-back" is rectified by components CR5 and C5, in the conventional manner and components R12 and C4 form a filter to smooth the pulsations of voltage across C5. V2 is a corona-discharge type regulator tube which regulates the high voltage to about 900 volts throughout the battery life. R11 is the geiger tube load resistor.

3.4 THE PULSE SHAPING AND METERING CIRCUIT:

The pulse shaping circuit is a blocking oscillator similar to the power supply with some exceptions. The circuit is held "cut-off" by the bias formed by

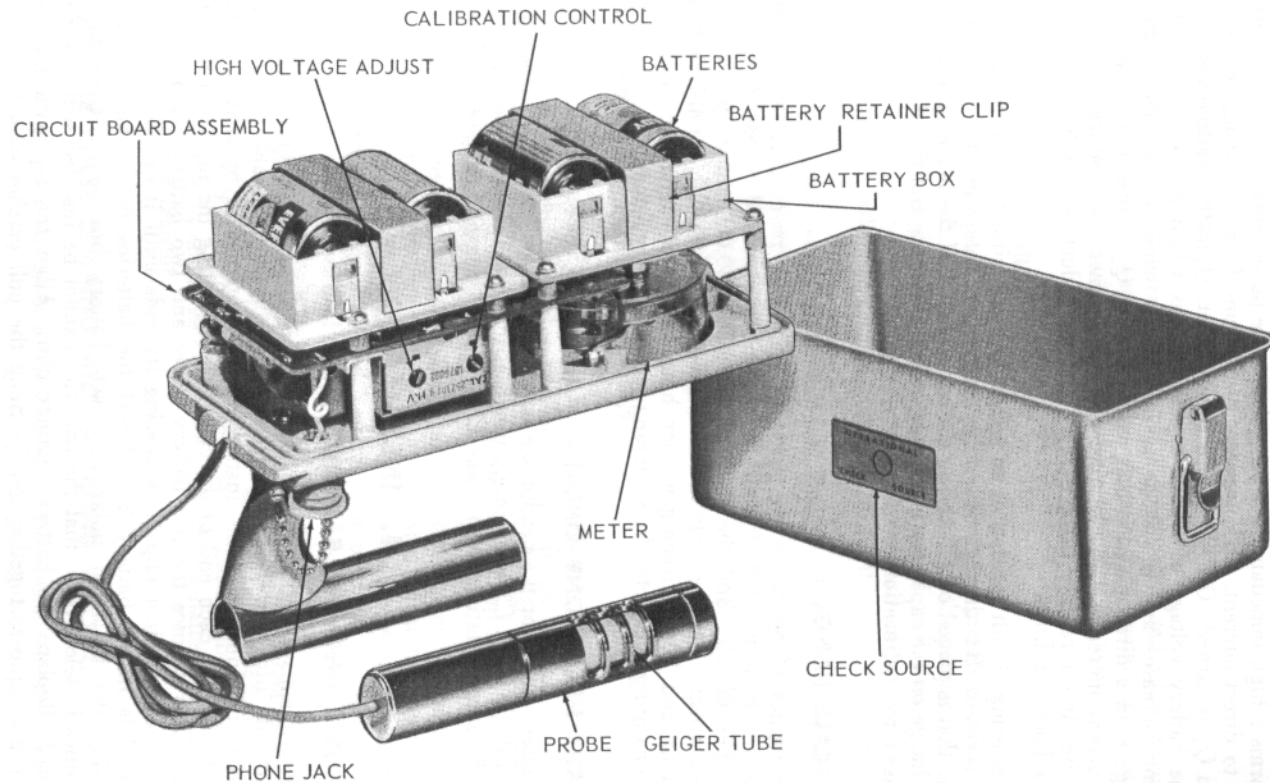

Figure 2. View of CD V-700, Model No. 6, Showing Major Components

5. OPERATION

5.1 OPERATING THE CIRCUIT THE FIRST TIME:

Clamp the circuit box back together and turn the switch to the X10 scale. Make certain that the sliding beta window of the probe is closed. Wait thirty seconds for the system to reach stability. The indicator should remain substantially at zero.

Open the window on the probe and present it to the center of the calibration source which is a beta radiation sample. The indicator should fall between 1.5 mr/hr and 2.5 mr/hr, averaging about 2 mr/hr.

5.2 CALIBRATION:

NOTE: The beta source must constitute the sole source of radiation when calibration is performed. Calibration must not be undertaken when the background is above normal or when the probe is in a radiation field other than that produced by the known beta source supplied with the instrument.

If the indication falls above or below this range, it may be corrected by the screw-driver adjustment inside the box which is marked "CAL". Advancing the adjustment clockwise increases the reading.

5.3 SCALE RANGES:

There is only one control on this instrument for the operator to use. It is the range control, comprising an "OFF" position and three ranges labeled, "X100, X10, and X1". These respectively are both 100 times, 10 times and 1 time the scale reading in milliroentgens per hour and counts per minute shown on the meter. This scale is 0.5 milliroentgens per hour and 300 counts per minute respectively with the major divisions all indicated on a 50-division scale.

5.4 USING THE HEADPHONES:

If the operator chooses to use a headphone with the instrument, it is screwed into the connector provided immediately to the left of the handle. The yellow plastic protective cap is removed. In using the headphone, the operator will note that each pulse arriving at the instrument is indicated by a distinctively audible "click" in the headphones.

5.5 NORMAL BACKGROUND:

Since normal background of radioactivity is of the order of 0.01 to 0.02 milliroentgens per hour, little activity will normally be observed. Under background conditions only about 20 per minute of these clicks occur and they are randomly spaced so that one may wait for several seconds before any

click is observed and then there may be two or three in rapid succession. Very accurate measurements of background and other low level radiation can be made by counting headphone clicks and timing with a watch which has a second hand. The procedure is to count a given number of counts and observe the time required to obtain these counts. The radiation rate in counts per minute is the number of counts divided by the time in minutes. Table 1 gives the number of counts that are required to provide a given percentage error where percent standard error is defined as that error for which in 68 cases out of 100 the true error will not exceed the given percentage error. The nine-tenths error is that error for which the true reading is no different from the observed reading within the given percentage limits for 90 cases out of 100.

TABLE I

Percent Error	Number of Counts Required For:	
	Standard Error	Nine-Tenths Error
1%	10,000 Counts	27,000 Counts
3%	1,100 Counts	3,000 Counts
10%	100 Counts	271 Counts

5.6 CHECKING CALIBRATION:

The operator should periodically check the calibration of the instrument to verify that it is correct. This operation is described in paragraph 5.2.

5.7 USING THE CARRYING STRAP:

The instrument may be carried in the hand or by a strap over the shoulder. The strap anchors are arranged in such a way that the meter is visible when carried over the right shoulder.

6. OPERATOR'S MAINTENANCE

6.1 BATTERY REPLACEMENT:

Battery replacement is easily accomplished by removing the circuit box bottom and the battery retaining clips on the two battery boxes. The old cells may be pulled out without tools and the new ones inserted.

7. PREVENTIVE MAINTENANCE

7.1 BATTERY LIFE:

CAUTION: Make certain the instrument is turned off at all times when not in use, otherwise the batteries will certainly be depleted and the instrument rendered ineffective. The life of the batteries in the rear battery box is about 100 hours under continuous operation and about 175 hours when operated four hours a day. The life of the other two cells is considerably longer but it is recommended that all batteries be replaced at one time. It is also recommended that the operator become accustomed to noting that the operating switch is in the "OFF" position when the instrument is set aside.

7.2 STORAGE:

For storage purposes it is best, wherever possible, to keep the instrument in a moderately cool area as this will provide greater shelf life for the batteries. At all times one should attempt to prevent radiological contamination of the instrument and particularly of the probe.

8. CORRECTIVE MAINTENANCE

8.1 REPLACING THE BATTERIES:

Battery replacement is accomplished as outlined in paragraph 6.1. The end point of the cells in the rear battery box is 1 volt per cell. The end point of the other cells is 2.5 volts for proper accuracy of the counting circuit. However, it is recommended that all batteries be replaced at one time in order that the shelf life of the counting circuit batteries is not exceeded.

8.2 REPLACING THE GEIGER TUBE:

The chief maintenance on this instrument is replacing the batteries. However, the geiger tube also expends itself with use and must be replaced occasionally but one cannot predict precisely the life of a geiger tube since the total number of counts it has accumulated and the operating conditions of temperature, voltage and load characteristics are very important. Whenever fresh batteries are installed into the instrument and the instrument does not work correctly, it is wise first to try replacing the geiger tube before making any further attempts at circuit checking.

8.3 CHECKING THE HIGH VOLTAGE SUPPLY:

When the power supply is operating, a buzz of about 100 cps. in frequency can be heard due to the oscillations of the power transformer laminations. If the buzz is not audible, the oscillator section is probably not operating

and the setting of R7B should be checked. This screw-driver adjustment is set properly by the following procedure:

- a. Insert a 0-100 millampere meter in series with the power supply batteries.
- b. Turn the "HV" adjustment full counter-clockwise.
- c. Turn the instrument "ON".
- d. Advance the screw-driver adjustment clockwise until the meter reads 33 milliamperes with new batteries.

The high voltage output of the power supply should be tested with an electrostatic voltmeter. The voltage should read 910 ± 10 volts. This voltage may also be measured with a 20,000 ohms-per-volt meter on the 5,000 volt range with new batteries in the instrument.

The nominal resistance values for the transformer are: winding 1-2, 4500 ohms; winding 3-4, 11 ohms; and winding 5-6, 5 ohms (all values $\pm 20\%$).

8.4 CHECKING THE PULSE SHAPING AND INTEGRATING CIRCUIT:

After continuity tests have been made, the integrating circuit should be tested further using an oscilloscope. The proper pulse waveshape on the collector of Q_1 is a positive 3 volt square wave of a nominal 150 microseconds in duration followed by a "fly-back" of about -20 volts in amplitude. If the waveshape at the anode of CR1 shows "ringing", CR1 is probably defective. Diodes CR1 through CR4 may be tested with an ohmmeter on the RX10,000 range. One end of the diode under test should be disconnected from the circuit for this test. (Diode CR5 in the high voltage power supply will not respond to this test.) The indication of a good diode is very low resistance with the ohmmeter leads connected a given way. With the leads reversed the resistance reading should be 100K ohms or greater for CR1, CR3, and CR4, and 1 megohm or better for CR2.

8.5 TESTING FOR PROPER OPERATION OF THE RANGE SWITCH:

The range switch may be tested with an ohmmeter for proper closure of the switch contacts. The power supply "ON-OFF" section of the switch may be recognized by the red battery lead and the emitter of Q_1 connecting to the switch. With the batteries removed, test for proper "ON-OFF" operation. A similar test can be made for "ON-OFF" operation of the counting circuit, with the ohmmeter connected to ground and to the black battery lead. To test the range circuit, connect the ohmmeter to ground and the negative (black end) terminal of 400 mfd capacitor C2, and read the following resistance values:

X100 range reads 1900 ohms, X10 range reads 200 ohms, and X1 range reads 16.5 ohms. (All values $\pm 5\%$). The batteries should be removed for all tests in this section.

9. REPLACEABLE PARTS LIST:

9.1 Electrical Components

12

Circuit Symbol	Description	Function	Manufacturer	Manufacturer's Part No.	Victoreen Part No.	Quantity Per Equipment	*Recommended Qty. for Plant & Field Maintenance
C1	Capacitor: .0039 uf; 1000V	Coupling Capacitor	CentraLab	DA 048 249CB	21-193	1	1
C2	Capacitor: 400 uf; 3V	Integrating Capacitor	Chemtronic Corp.	20-437BP 400-3D65	21-87	1	1
C3	Capacitor: .033 uf; 75V	Headphone Pulse Stretcher	J. E. Fast Co.	4-21365-3	21-194	1	1
C4	Capacitor: .001 uf; 1000V	By-Pass Capacitor	Radio Mat'ls. Corp.	B.001 Discap	21-43	1	1
C5	Capacitor: .01 uf; 1600V	By-Pass Capacitor	Good-All	H1-KB	21-23	1	1
CR1	Diode: 1N34 (or equiv.)	Damper	C.B.S. Electronic Sales Corp.	1N34	389-133	3	5
CR2	Diode: PA305A (or equiv.)	Meter Rectifier	Radio Receptor	PA-305A	489-18	1	5
CR3	Same as CR1	Headphone Coupling	—	—	—	—	5
CR4	Same as CR1	Damper	—	—	—	—	5
CR5	Selenium Rectifier	H. V. Rectifier	International Rectifier Corp.	T35HP	489-17	1	1
J1	Phone Jack Assembly	Aural Indicator	Victoreen	700-102	700-102	1	1
L1	Choke: 8.2 mh	GM Tube Load	J. W. Miller Co.	981	700-99	1	2
M1	Meter Assembly: 0 - 50 uA dc	Visual Indicator	Victoreen	700-95	700-95	1	5
Q1	Transistor	Ratemeter Transistor	Victoreen	23-17	23-17	1	1
Q2	Transistor	Power Supply Transistor	—	23-6	23-6	1	1
R1	Resistor: 1900 ohms; ½W; 5%	X100 Range Multiplier	Victoreen	185-1412	185-1412	1	1
R2	Resistor: 220 ohms; ½W; 5%	X10 Range Multiplier	International Resistance Corp.	50-65	185-560	1	1
R3	Resistor: 11 ohms; ½W; 5%	½ of X1 Range Multiplier	International Resistance Corp.	50-65	185-429	1	1

9.1 Electrical Components (cont'd)

R4	Resistor: 7 ohms; WW; 5%	1/2 of X1 Range Multiplier	Victoreen	185-1411	185-1411	1	1
R5	Resistor: 2.7k ohms; 1/2 W; 10%	Meter Time Constant	International Resistance Corp.	50-65	185-252	1	1
R6	Resistor: 4.7k ohms; 1/2 W; 20%	1/2 of Calibrate Resistance	International Resistance Corp.	50-65	185-1303	1	1
R7A	Potentiometer: 50k-5k ohms	1/2 of Calibrate Resistance	Stackpole Carbon Co.	DVV 5K 25K	22-6	1	1
R7B	Section of R7 5k ohms	Power Supply Adjust	—	—	—	—	1
R8	Resistor: 1.2k ohms; 1/2 W; 10%	Headphone Decoupler	International Resistance Corp.	50-65	185-633	1	1
R9	Resistor: 1.5k ohms; 1/2 W; 10%	1/2 of Ratemeter Bias	International Resistance Corp.	50-65	185-351	1	1
R10	Resistor: 100 ohms; 1/2 W; 10%	1/2 of Ratemeter Bias	International Resistance Corp.	50-65	185-118	1	1
R11	Resistor: 1 Meg; 1/2 W; 20%	GM Tube Load	International Resistance Corp.	50-65	185-1305	2	1
R12	Same as R11	Filter	—	—	—	—	1
S1A	Switch	Range Switch	Victoreen	700-6	700-6	1	1
S1B	Section of S1	Range Switch	—	—	—	—	1
S1C	Section of S1	Range Switch	—	—	—	—	1
T1	Transformer Assembly	Pulse Transformer	Victoreen	700-98	700-98	1	1
T2	Transformer	"Fly-Back" Transformer	Victoreen	700-14	700-14	1	1
V1	Geiger Tube: 6993	Detecting Element	—	—	700-13	1	5
V2	Tube, GV3A: 900V	Corona Voltage Regulator	Victoreen	CPO-240	CPO-240	1	5
BT1	Battery: 1.5V NEDA type 13	Power Supply Battery	Union Carbide Consumer's Prod. Co.	950	263-17	4	10
BT2	Same as BT1	Power Supply Battery	—	—	—	—	10
BT3	Same as BT1	Ratemeter Battery	—	—	—	—	10
BT4	Same as BT1	Ratemeter Battery	—	—	—	—	10

*Quantity of field and plant maintenance supply parts based on five instruments for one year.

9.2 Mechanical Components

Description	Function	Manufacturer	Manufacturer's Part No.	Victoreen Part No.	Quantity Per Equipment	*Recommended Qty. for Plant & Field Maintenance
Headset	Aural Indicator	Superex Electronics Inc.		700-16	1	2
Phone Plug	Headset Connection	Switchcraft	2501F	700-57	1	2
Strap Buckle	Carrying Strap Length Adjustment	Waterbury Buckle Co.	807 5047	710-44	2	4
Strap Fastener	Attaches Shoulder Strap to Instrument	Victoreen	700-82	700-82	2	4
Shoulder Strap	Carrying Strap	Victoreen	700-81	700-81	1	2
Case Bottom & Clamp Assembly	Bottom Case of Instrument	Victoreen	700-101	700-101	1	2
Battery Retainer Clip	Holds Batteries in Battery Box	Victoreen	720-121	720-121	2	6
Battery Contact	Electrical Connections to Batteries	Victoreen	700-68	700-68	8	25
Knob	Operating Control Knob	H. Davies Molding Co.	1500K	710-85	1	3
"O" Ring	Switch Shaft Seal	Parker Appliance Co.	5427-1	710-42	1	3
Grommet	Holds (V2) Tube	Philpott Rubber Co.	CB-225	373-75	1	5
Tube Clip	Holds V2 Tube to Circuit Board	Victoreen	700-94	700-94	1	5

9.2 Mechanical Components (cont'd)

Transformer Bracket	Supports H. V. Transformer	Victoreen	700-96	700-96	1	5
Seal Nut	Clamps Probe Cable	Victoreen	700-72	700-72	1	5
Rubber Gland	Seals Probe Cable	Victoreen	700-71	700-71	1	5
Probe Assembly	Sensing Element	Victoreen	700-75	700-75	1	3
Gasket	Seals Probe	Victoreen	700-79	700-79	1	5
Probe Shield Retaining Spring	Holds Probe Shield in Place	Victoreen	700-87	700-87	1	5
Detent Ball	Positions Sliding Probe Shield	New Departure	1/16" Ball 440SS Gr2	700-89	1	5
Detent Spring	Holds Detent Ball in Place	Victoreen	700-85	700-85	1	5
End Cap	End Cap of Probe	Victoreen	700-78	700-78	1	5
Probe Clip	Holds Probe to Case Handle	Victoreen	700-61	700-61	1	5
Cap Plug & Chain Assembly	Covers Phone Jack	Victoreen	700-65	700-65	1	5
"O" Ring	Seals Probe Stand	Parker Appliance Co.	2-9	46-25	1	5
Probe Stand Handle	Carry Handle of Instrument	Victoreen	700-73	700-73	1	5
"O" Ring	Seals Phone Jack	Parker Appliance Co.	2-12	790-24	1	5
Meter Gasket	Water-Tight Seal Between Case Top and Meter	Victoreen	700-63	700-63	1	5
Case Gasket	Water-Tight Seal Between Case Top & Case Bottom	Victoreen	720-157	720-157	1	10
Case Top	Top Case of Instrument	Victoreen	700-59	700-59	1	5
Instruction Manual	Operating Instructions	Victoreen	700-108	700-108	2	10

*Quantity of field and plant maintenance supply parts based on five instruments for one year.

9.3 List of Manufacturers

CBS ELECTRONICS SALES CORPORATION, 100 Endicott Street, Danvers, Massachusetts
CENTRALAB, INCORPORATED, 900 East Keefe Avenue, Milwaukee, Wisconsin
CHEMTRONIC CORPORATION, 309 Eleventh Avenue, Nashville, Tennessee
GOOD-ALL ELECTRIC MANUFACTURING COMPANY, 112 W. First Street, Ogallala, Nebraska
HARRY DAVIES MOLDING COMPANY, 1428 North Wells Street, Chicago 10, Illinois
INTERNATIONAL RECTIFIER CORPORATION, 1521 E. Grand Avenue, El Segundo, California
INTERNATIONAL RESISTANCE COMPANY, 401 N. Broad Street, Philadelphia, Pennsylvania
JOHN E. FAST COMPANY, 3580 North Elston Avenue, Chicago, Illinois
J. W. MILLER COMPANY, 5917 South Main Street, Los Angeles, California
NEW DEPARTURE DIVISION, GMC, 53 Purchase Street, Bristol, Connecticut
PARKER APPLIANCE COMPANY, 17325 Euclid Avenue, Cleveland 12, Ohio
PHILPOTT RUBBER COMPANY, 2077 East 30th Street, Cleveland 15, Ohio
RADIO MATERIALS CORPORATION, 3325 North California Avenue, Chicago, Illinois
RADIO RECEPTOR COMPANY, INCORPORATED, 240 Wythe Avenue, Brooklyn, New York
STACKPOLE CARBON COMPANY, St. Mary's, Pennsylvania
SUPEREX ELECTRONICS, INCORPORATED, 4-6 Radford Place, Yonkers, New York
SWITCHCRAFT, 1328 North Halsted Street, Chicago 22, Illinois
UNION CARBIDE CONSUMERS PRODUCTS COMPANY, 30 East 42nd Street, New York, N. Y.
VICTOREEN INSTRUMENT COMPANY, 5806 Hough Avenue, Cleveland 3, Ohio
WATERBURY BUCKLE COMPANY, 862 South Main Street, Waterbury 20, Connecticut

